

INSTRUCTIONS FOR INSTALLING

No. 52 and No. 52-F Water-Boy High-Duty Water Feeder

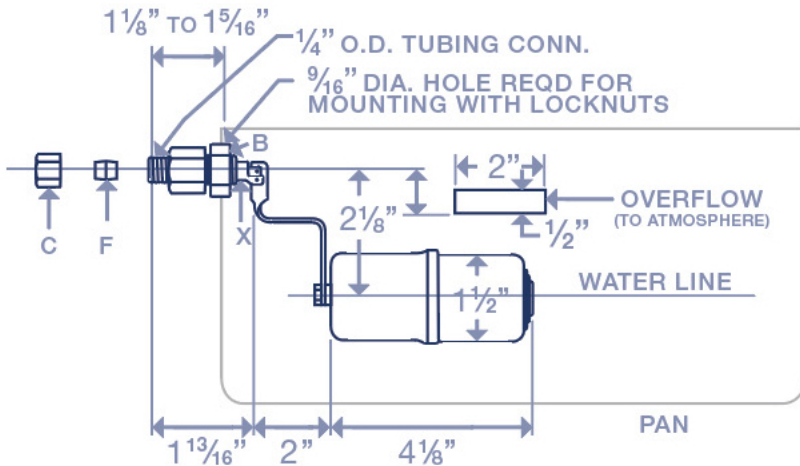

1. If not provided, drill $\frac{9}{16}$ " hole in convenient place 1" below top of pan and 1" above open airflow to conform with plumbing code back siphonage ordinance.
2. Insert water feeder valve into hole as shown. Replace locknut "B" making it tight against wall of pan.
3. Be sure hole "X" is in a straight down position.
4. Connect float lever to valve with cotter pin provided. Adjust for water level by bending float arm up or down.
5. When installing No. 52-F drill $\frac{1}{4}$ " hole in water pipe - cold water line preferably in hard water areas.
6. Screw bottom saddle half on needle valve and place leather washer around tube "E". Insert tube "E" into $\frac{1}{4}$ " hole drilled in water pipe and bolt top half of saddle on tight.
7. Connect to float valve with $\frac{1}{4}$ " copper tubing. Remove couplings "C" and slip onto $\frac{1}{4}$ " OD copper tubing. Next - slip sleeve "F" on the copper tubing. Insert copper tubing in valve end and tighten couplings with two wrenches — one on coupling and the other on valve. Make certain that hole "X" still remains in straight down position after tightening coupling.

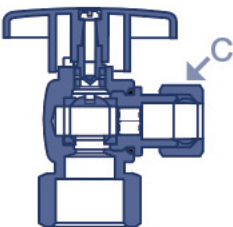

Maid-O'-Mist®

Manufacturing the finest plumbing products since 1932.

www.maidmist.com • 773-685-7300 ©2020 Maid-O'-Mist